

Research Journal of Pharmaceutical, Biological and Chemical Sciences

Non-Traditional Methods Of Increasing The Reproductive Qualities Of Animals.

Patieva A Mikhaelinovana¹, Kulikova N Ivanovna¹, Patieva S Vladimirovna¹,
Butore Joseph², Ntunzwenimana Mélance², and Nimbona Constantin^{1*}.

¹Kuban State agrarian University, Kalinina Street, 13, Krasnodar, Russian Federation

²University of Burundi, Faculty of Agronomy and Bio-engineering, Bujumbura, Burundi

ABSTRACT

The industrial technologies of milk production are accompanied by negative factors that cause frequent violations of the function of the reproductive organs in highly productive cows, inhibition and extinction of sexual reflexes from negative technological factors occurs: lack of active exercise and in solation, excess of ammonia in the air, carbon dioxide gas, high humidity, the movement of animals on wet and slippery floors, in conditions of loose litter, inaccuracies in feeding, an abundance of stress, associated with the implementation process. In this case, the cows reduce the duration of the immobility reflex; there is an increase period of "quiet estrus" up to 30 hours or more. The period of eggs ovulation changes because of hormonal imbalance due to disruption of the sexual glands, manifestation of ovarian hypo function. From practical observations, 20% of cows have delayed ovulation, and then involution of the uterus after calving continues. In this regard, the fecundation after insemination of cows decreases. Medicines, hormones and physiotherapy methods are used to stimulate sexual cycles and to increase the fertility of cows, since without them it is not possible to solve practically the problem of their reproduction. At the same time, it is not economically advantageous to use expensive drugs. We have developed and tested non-traditional methods for improving the reproductive qualities of animals.

Keywords: Cows, reproductive function, vibrating massage, hormonal status, fertilization

**Corresponding author*

INTRODUCTION

Intensification of animal husbandry breeding aims to increase the genetic potential of animals, the widespread use of physiological reserves to enhance the productive and protective properties of animals [2,6]. It is known that the reproduction of the herd is the most difficult and laborious process in dairy cattle breeding, and the industrial technology conditions of milk production is large complex, the mechanization of farms is even more complicated. This is facilitated by a number of factors that negatively affect the function of the reproductive system of animals [4,5,7].

Various techniques contribute to the normalization of the reproductive organs functions of the animals. These include the introduction of sponges containing a gestagen or hyaluronidase enzyme into the vagina of animals, and intramuscular injections of oestrophan. The use of high doses of gonadotrophin releasing hormone (GnRH) is recommended to induce the ovulation in order to accelerate ovulation and synchronization of estrus, and the administration of benzoate gonadotropin-estradiol. To increase the reproductive function of cows and heifers, a single injection of prolonged-action steroids-17-hydroxyprogesterone caproate was adopted and 30 to 80% of animals had manifested estrus on days 16-22 [1,8,9].

Despite the high effectiveness, the use of hormonal medicines does not always meet the requirements: this is the high cost of drugs, their deficiency, not always and the possibility of their introduction to animals for veterinary and other reasons.

In practice, massage of the genital organs of cows is used to obtain a similar effect: with ovarian hypofunction, the fastest restoration of reproductive abilities, the normalization of the sexual organs after calving, the preparation of the reproductive organs for insemination, massage the uterus and ovaries in cows through rectum for 2-3 minutes in combination with irrigation with a 1% solution of NaCl at a temperature of 43-45 °C.

A common drawback of these methods of reproductive stimulation of genital organs is the use of manual labor. In medical practice for the stimulation of sexual functions, vibrational massage with endocrine infertility, ovarian hypofunction was widely used. There are known works on testify to the influence of vibro massage on the sexual function of animals. An experimental and clinical studies have established that vibro massage of the genital organs of laboratory animals causes an increase in metabolism in tissues, a change of biological parameters in blood, an increase in protein synthesis, promotes the accumulation of glycogen, ascorbic acid, increases oxidation-reduction processes, and increases energy metabolism in the body. The mechanical vibrations stimulate the excretory function of many glands [3].

In connection with this, it is of scientific practical interest to use such unconventional techniques in dairy cattle breeding, such as vibrating massage of reproductive organs and studying its effect on animals.

This research aims to study the influence of vibro massage on the hormonal status, the postpartum involution of the uterus after calving and stabilization of the sexual cycles. The research tasks included:

- a) the determination of the site of localization and modes of vibration stimulation of cows;
- b) the determination of the effectiveness of stimulation by hand and vibromassage;
- c) the determination of the concentration of sex hormones in the serum under the influence of vibromassage;
- d) the evaluation of the results of insemination and fertilization of cows.

MATERIALS AND METHODS

The one of our objectives include studying the variation of hormones' concentration under the influence of stimulation by directional vibrating massage on the reproductive organs of cows and, to assess the effect of vibrational massage on the hormonal status and reproductive properties of cows.

To solve the set tasks, we have formed 2 groups of experimental and control animals with close calving dates, live weight, and health status. The experimental groups were formed according to the principle

of pairs-analogues. We targeted the re-establishment of estrogenic background in order to complete the involution of the uterus after calving at the micro anatomical level, and stabilize the sexual cycles.

The tests were carried out at the Russian State Pedagogical University Maistrenko and in the military farm "Angelinsky" of the Krasnoarmeysky district. To achieve this goal, methods were used to synchronize estrus and stimulation of estrogen activity in the ovaries of cows and heifers and we used the device developed in the patent RF No. 1811821, No. 20115692 to implement the method.

Characteristics of the device. The device (Figures 1, 2) is a massage element (1) connected to a source of pulsating vacuum by a spring-loaded bellows (2) and fastening equipment (3), which is also a handle-holder.

The massage element is made of the form of an oval concave disc with an elastic surface, a congruent surface of the vulva. The oval shape and the concave surface of the massage element make it possible to achieve a complete fit of the device to the surface of the vulva skin. The mounting hardware (4), hollow inside, is connected to the pulsating vacuum of the milking unit (7) by means of a flexible hose (5) and a pulsator (6).

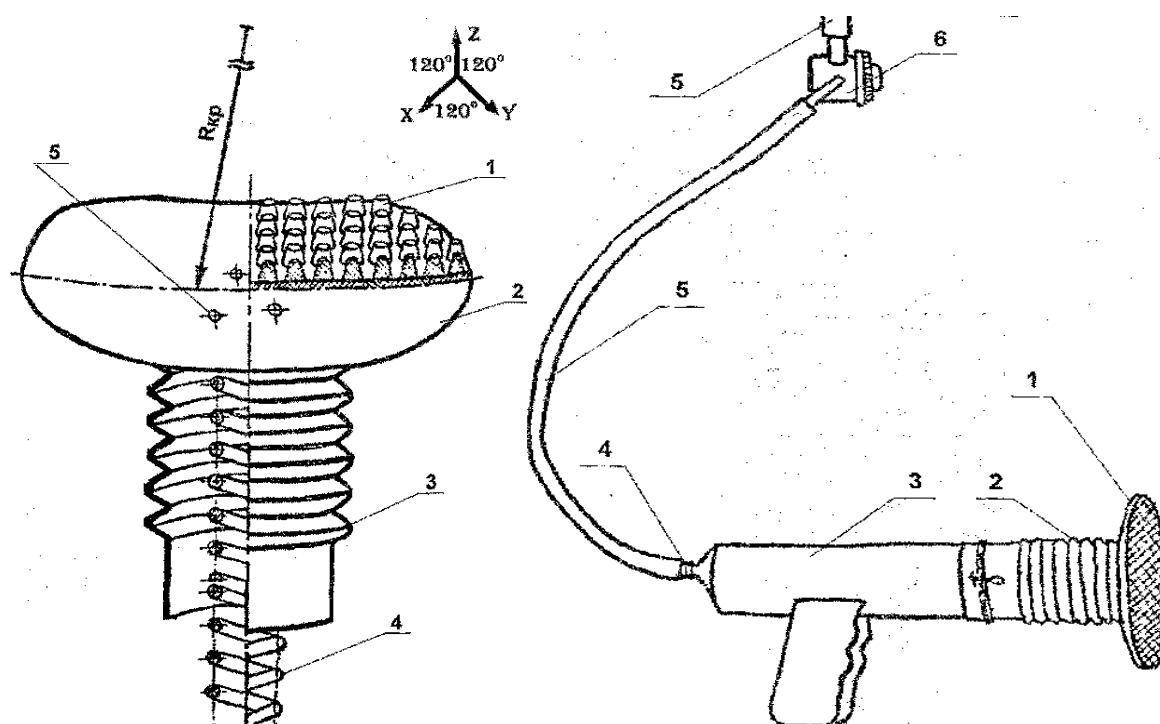

Fig 1: Device for massage of reproductive organs of animals Fig 2: The device's massage element

The device operates as follows: when the device is connected to a vacuum source (7) through the pulsator (6), a high-vacuum portion is fed through the branch pipe (4) and hollow handle-holder (3) into the bellows (2). As a result, the spring-loaded bellows compresses, pulling the massage element (1) away from the surface of the vulva. At the subsequent portion of low vacuum, the compression of the bellows stops, the compressed spring inside the bellows tends to straighten, facilitating the straightening of the bellows and moving the massage element to the surface of the vulva, pushing it. Then follows the flow of a portion of high vacuum, the working process is repeated. The required frequency of movement of the massage element is established by the regulation of the pulsator.

The choice as application place of the vibratory massage of the surface of the vulva is made based on the theory of vegetative-segmental physiology. Since it is known that the most pronounced reaction from organs and tissues can be obtained by the action of vibrating massage on various parts of the skin, which are well innervated and genetically related. The surface of the vulva meets these requirements since it represents the reflex ogenic zone and part of the reproductive system of the animal. The effects applied to the surface of the skin are perceived by a multitude of nerve formations located in its tissues. And vibro massage applied to

the reflex genic zone is a strong stimulant that enhances efferent impulses from peripheral receptors to the central nervous system.

As a result of this vibro massage, the tone of the circulatory system of animal's increases and blood flow is accelerated, the blood circulation and function of glands and organs improve, in this case the activity of the ovaries is intensified.

The rhythm of complete sexual cycles is normalized by the effects of vibration, the percentage of animal's fertilization increases. This allows to ensuring the optimal level of reproduction with the existing technology of industrial milk production.

The use of this method helps to reduce the consumption of sperm for repeated insemination, allows fruitful insemination of animals in time optimal for animals and farms. The methods of estrus synchronization and stimulating ovarian estrogen activity in cows and heifers, depending on their condition, include the following methods:

1. The vibrators are applied to the cows from the 15th day after calving, during 5 sessions lasting 3 minutes after 24 hours on the vulva with subsequent insemination.
2. Cows with atony of the uterus, according to the conclusion of a veterinarian-gynecologist, spend vibro-massage for 10 session's course of 3 minutes each, after 24 hours on the vulva area.
3. Cows receive a 3 minutes vibro-massage session on the vulva 10 to 15 minutes before artificial insemination,
4. In heifers meeting the reproductive requirements, heat synchronization and stimulation of estrogenic activity of the ovaries, a 3 minutes vibration per day in the vulva were applied 10 days before the expected insemination,
5. For rapid re-establishment of reproductive capacity, vibro-massage was applied to the vulva of cows in postpartum period for 3 minutes and 2 to 3 times a week, starting 3 to 5 days after calving.

RESULTS AND DISCUSSION

To study the effect of directed vibro massage on the hormonal status, the blood serum of the experimental animals was examined. Blood for research was collected from animals at the beginning – when, in the middle of the experiment and before calving.

The determination of hormones in the serum was performed by radio immunological method. The results of the studies are presented in table 1.

Table 1: Hormonal status of cows under the influence of vibro massage in dynamics with the development of pregnancy

Hormon	Experiment group	Hormone					
		at the beginning		in the middle		before calving	
		n	M±m	N	M±m	n	M±m
Cortisol, ng/ml	Control	13	14,62±0,91	15	15,73±2,24	15	12,20±2,36
	experimental	15	10,40±0,85	15	13,67±2,01	15	9,80±1,53
Estradiol, ng/ml	control	13	29,92±3,84	15	37,67±2,59	15	50,93±9,39
	experimental	15	27,73±1,31	15	37,67±4,86	15	65,13±14,35
Progesterone, ng/ml	control	13	1,84±0,19	15	2,63±0,21	15	1,16±0,24
	experimental	15	2,29±0,35	15	4,12±0,48	15	1,21±0,20
Prolactin, Ng/ml	control	13	66,45±21,09	15	58,19±18,98	15	136,40±65,37
	experimental	15	20,08±5,25	15	47,88±11,77	15	55,51±23,91

During the tests, it was found that with manual traditional massage of the genital organs (uterus, ovaries) through the rectum from the 18th day after calving and subsequent insemination, 8 animals (out of 15)

or 53.3% were fertilized, and there were cases of trauma to the mucosa vestibule of the vagina and rectum. The test results are presented in Tables 2, 3 and 4.

Table 2: Influence of stimulation on the results of insemination of cows

Groups of animals	Method of stimulation	inseminated		% of productive insemination
		Number of inseminations, cows	Number of productive insemination, cows	
Control	Manual massage of the genital organs of cows, rectally	15	8	53,3
experiment	Stimulation of the vibro-massaging area of the vulva of cows	15	11	73,3

The zoo technical expediency of observing the results of experiments under production conditions was manifested in an increase in the sexual activity of the experimental animals. So, in cows under stimulation, the rhythm of full sexual cycles was normalized. This was confirmed by an increase in the percentage of actual pregnancy inseminated after stimulation of animals.

Table 3: Fertility and seed consumption

Group of animals	n	Method of stimulation	Number of inseminations for the period of the experiment		Fertilized insemination	
			total	per head	total	%
control	25	Manual massage of the genital organs of cows, rectally	51	2,03	13	52,0
experimental	27	Stimulation of the vibro-massaging area of the vulva of cows	48	1,78	21	77,8

Table 4: Influence of vibro-massage of vulva of cows on their reproductive qualities

Group of animals	n	Service Duration		Fertilized inseminations	% of productive inseminations
		Lim	M		
control	24	42-117	107,12	13	54,16
experimental	27	30-183	91,60	20	74,07

When stimulating by vibro-massage of the outer region of the cows' vulva from the 18th day after calving (frequency of vibration 10-15 Hz, amplitude of oscillations 1-3 mm), 11 of the 15 experimental animals were fruitfully inseminated, which amounted to 73.3%. There were no cases of trauma to the vulvar mucosa. The animals were stimulated daily during 3 minutes.

Based on a visual examination of the genitals (with swelling of the vulva, the expiration of the transparent stretching mucus), a decision was made about artificial insemination. The average term of fruitful insemination from the beginning of stimulation of the animals of the control group was 6.6 days and 4.3 days, in animals in the experimental group. It should be noted that in the animals of the experimental group, the involution of the reproductive organs and the stabilization of sexual cycles began 2.3 days earlier.

To determine the effectiveness of stimulation of the cow' vulva area on the synchronization of estrus and the associated repetition of insemination and seed consumption, clinically healthy animals were selected on the day 30th after calving. Their reproductive organs were stimulated, and these cows were artificially inseminated. The cows of the control group underwent a rectal massage of the uterus and ovaries, and a vibratory massage of the vulva area was performed in the experimental group. Stimulation was carried out daily, after 24 hours during 3 minutes. The presence of swelling of the vulva, outflow from the sexual slit of the stretching transparent mucus was considered a readiness of the animal for fertilization.

The stimulation of reproductive organs contributed to a reduction of repeated inseminations and the use of doses of sperm for one fruitful insemination by 12.32%. The reduction of sperm consumption is explained by the fact that as a result of the vibro-massage of the vulva area, estrogenic activity of the ovaries was stimulated, which in turn influenced the synchronization of sexual cycle.

To study the effect of stimulation of the vulva on the duration of the service period, we selected a herd with a large service period. Two groups of animals were formed from them according to the principle of para- analogues, the experimental and control groups were determined by lot-drawing. The results obtained in the experiment testify to the effectiveness of the method of synchronizing sexual estrus and stimulating estrogenic activity of the ovaries in experimental animals. Out of 27 experimental group cows with an average service period of more than 3 months, 20 (74.07%) went in estrus and fruitfully inseminated, and in the control group only 54.16% of cows were fruitfully inseminated.

CONCLUSIONS

Based on the results of the research, we recommend to intensify the process of postpartum involution of the uterus in cows after calving, to stabilize the sexual cycles, to increase fertility with reduced consumption of semen doses, to increase milk production, we consider it expedient to introduce the proposed method of improving the technological qualities of animals.

REFERENCES

- [1] Danilo D, Darren DH, Vitor RG, et al., Brazilian archives of biology and technology, Vol.57, 2014, №3, 361 – 366.
- [2] Kulikova NI, Eremenko ON, Malakhova AO. Pat. №. 2623169. Russian Federation IPC A 01 / K 67/02., 2017.
- [3] Lakamy S, Claudio P, Giuseppe S, Antonio V, Maurizio M, Theriogenology, Vol. 83, 2015, 779-785.
- [4] Mihayluk PM, Patieva AM, Patiev AZ, Komlatsky VI, Pat. №. 4916934, Russian Federation, Krasnodar, 2000.
- [5] Mikhailuk PM, Patieva AM, Patiev AZ, Komlatsky VI, Pat. № 1811821, Russian Federation, 2000.
- [6] Nekrasov AA, Popov NA, Fedotov, YeG, Dairy and beef cattle breeding, 2017, №. 2, p 17 – 20.
- [7] Patieva AM. Agricultural Sciences, Krasnodar, 2000, 51.
- [8] Reuben JM, Gabriel A Bo. *Reprod. Fertil. Dev.*, 2011, 24(1), 278 – 283.
- [9] Tsung-Ching LC, Fei Chiang C, Tang Ho JP, Wen C. *Theriogenology*, 2018, 105, 45 – 50.